

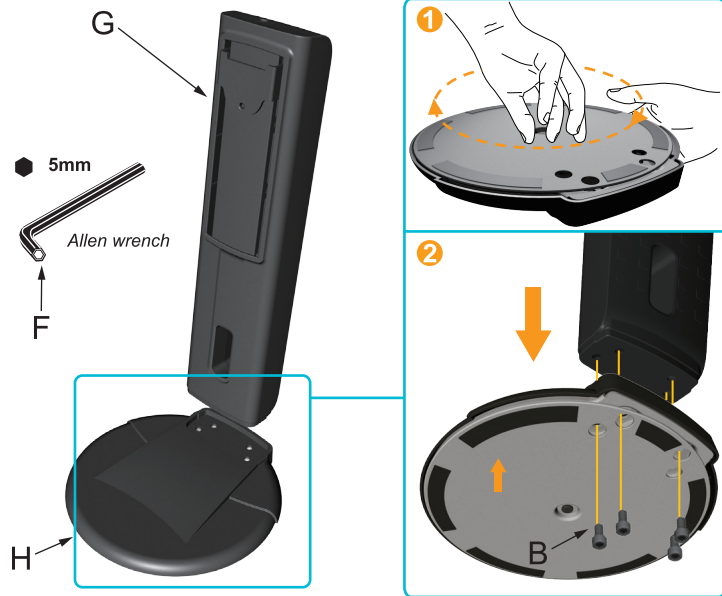

Installation Process

Step 1



Step 2

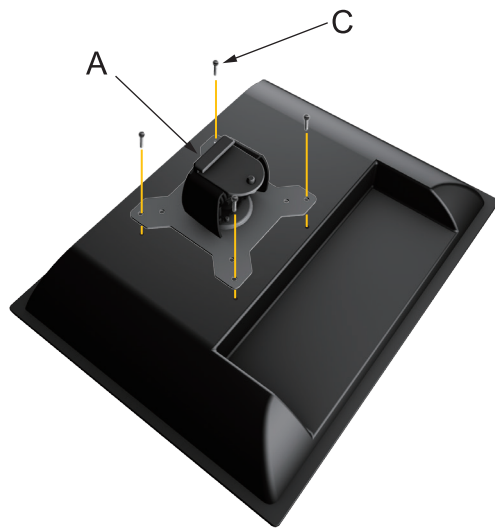

Step 3



Swivel&Tilt / Rotate

Cable Management

Height Adjust

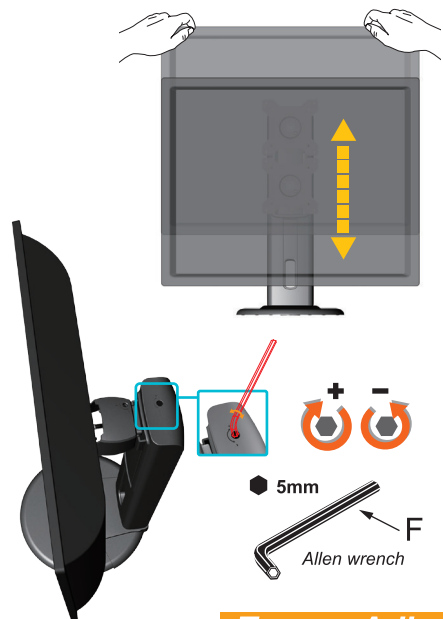

Torque Adjust

Tilt

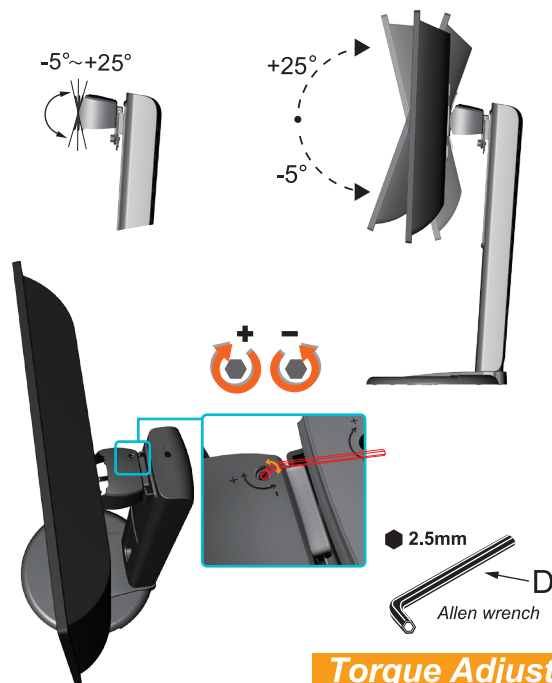

Torque Adjust

Rotate

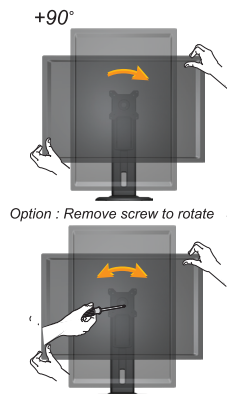

Swivel

Swivel

360°

